



INSTRUCTION MANUAL



NANO Q4 CAM PLUS
NO. H002

Content

Introduction-----	1
Safety Notes-----	1
Safety check before flying-----	3
Charge the Li-Po battery-----	3
Remote Controller-----	5
Camera-----	6
Start to Fly-----	7
Advanced Performance Setup-----	9
Propellers-----	11
Exploded View-----	12
Troubleshooting-----	13
Spare Part List-----	14

1 Introduction

Thank you for buying the HUBSAN products. It is designed as an easy-to-use, multi-functional RC model, capable of hovering, fast forward and acrobatic flight maneuvers. Please read the manual carefully and follow all the instructions. Be sure to keep the manual for future reference.

2 Safety Notes

2.1 Important Notes

This multi-functional RC model is not a toy.

In case of any injuries caused by improper operations, please read the instructions carefully before use. Be aware of your personal safety, safety of others and your surrounding environment. It is advised that beginners learn to fly the quadcopter under the guidance of professional

2.2 Caution

Propellers work in high speed, which may cause dangerous. User will be responsible for any damages caused by improper operations.

Do not operate the quadcopter in crowds, buildings, airports or nearby high voltage cables.

2.3 Li-Po Battery Safety Notes

The quadcopter is powered by a Lithium-Polymer battery.

If you do not plan to use the products for a long time, store the battery approximately 50% charged to maintain battery performance and life.

Important

- Risk of explosion if battery is replaced by an incorrect type.
- Dispose of used batteries according to the local regulations.



SAFETY ADVISORY NOTICE

Lithium-Polymer (LiPo) Batteries

LiPo batteries are different from conventional batteries in that their chemical contents are encased in a relatively lightweight foil packaging. This has the advantage of significantly reducing their weight, but does make them more susceptible to damage if roughly or inappropriately handled. As with all batteries, there is a risk of fire or explosion if safety practices are ignored:

- ☑ Charge and store LiPo batteries in a location where a battery fire or explosion (including smoke hazard) will not endanger life or property.
- ☑ Keep LiPo batteries away from children and animals.
- ☑ Never charge the LiPo battery that has ballooned or swelled.
- ☑ After a crash, inspect the battery pack for the sign of damage. Discard in accordance with your country's recycling laws.
- ☑ Never charge the LiPo battery in a moving vehicle.
- ☑ Never overcharge the LiPo battery.
- ☑ Never leave the LiPo battery unattended during recharging
- ☑ Do not charge LiPo batteries near flammable materials or liquids.
- ☑ Ensure that charging leads are connected correctly. Reverse polarity charging can lead to battery damage or a fire or explosion.
- ☑ Have a suitable fire extinguisher (electrical type) OR a large bucket of dry sand near the charging area . Do not try to extinguish electrical (LiPo) battery fires with water.
- ☑ Reduce risks from fire/explosion by storing and charging LiPo batteries inside a suitable container.
- ☑ Protect your LiPo battery from accidental damage during storage and transportation. (Do not put battery packs in pockets or bags where they can short circuit or can come into contact with sharp or metallic objects.)
- ☑ If your LiPo battery is subjected to a shock (such as a crash), place it in a metal container and observe for signs of swelling or heating for at least 30 minutes.
- ☑ Do not attempt to disassemble or modify or repair the LiPo battery.

2.4 Prevent Moisture

The quadcopter contains many precision electrical components. Store the battery and the quadcopter in a dry area at room temperature. Exposure to water or moisture may cause malfunction resulting in loss of control.

2.5 Proper Operation

For safety, only use Hubsan spare parts for replacement.

2.6 Always Be Aware of the Rotating Propellers

Be careful to keep your body away from the working propellers. Always keep the quadcopter fly in sight. If above mentioned happens, power off the quadcopter and the remote controller immediately.

2.7 Avoid Flying Alone

Beginners should avoid flying alone when learning flight skills.

3 Safety Check Before Flying

- Before flight, check the batteries of quadcopter and controller are fully charged
- Before power on the remote controller, check the throttle stick is fully down
- Check the quadcopter is in good condition, broken parts will cause a risk of injury
- Always power on the remote controller first, then quadcopter. After using, always power off the quadcopter first, then remote controller. Improper procedure may cause the quadcopter lose of control.

4 Charge the Li-Po Battery

4.1 3.7v180mAh Li-Po Battery

Connect the battery to the Hubsan USB charger, then connect the USB charger to USB devices, such as a computer or mobile power charger. It takes around 30 minutes to fully charge the battery. The USB LED indicator is in red when charging and light off when the battery is fully charged. Please unplug the charger and battery when the charging is completed. Flight time is around 6 minutes.

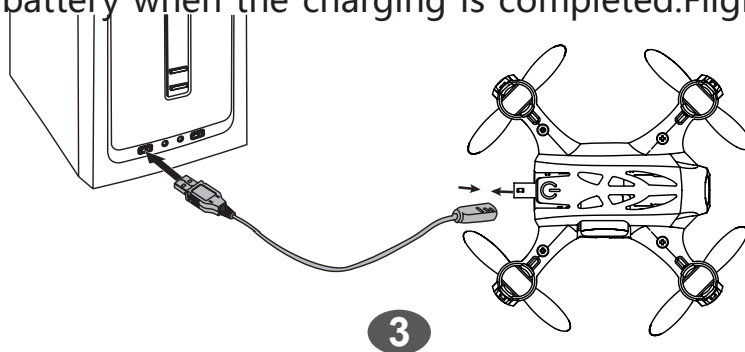

4.2 Power-on/off

Long press the power button to turn on/off the quad.

(As shown in the picture)

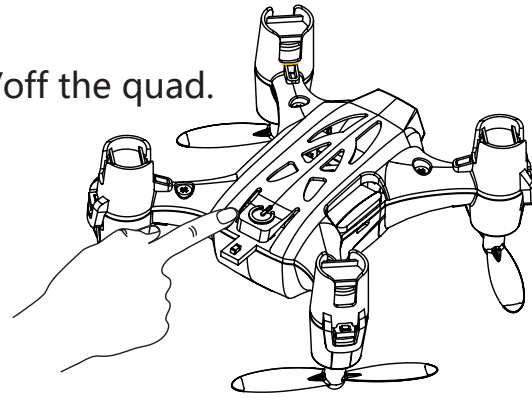

5 Remote Controller

Mode 1

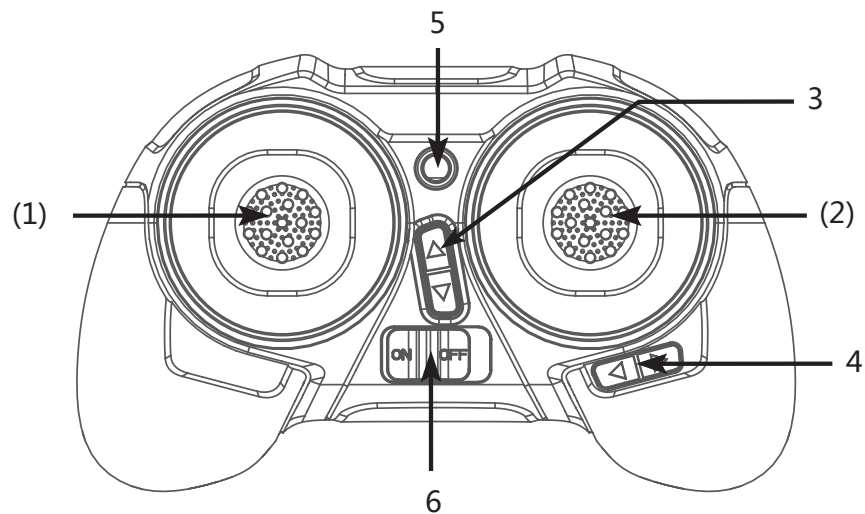

Mode 2

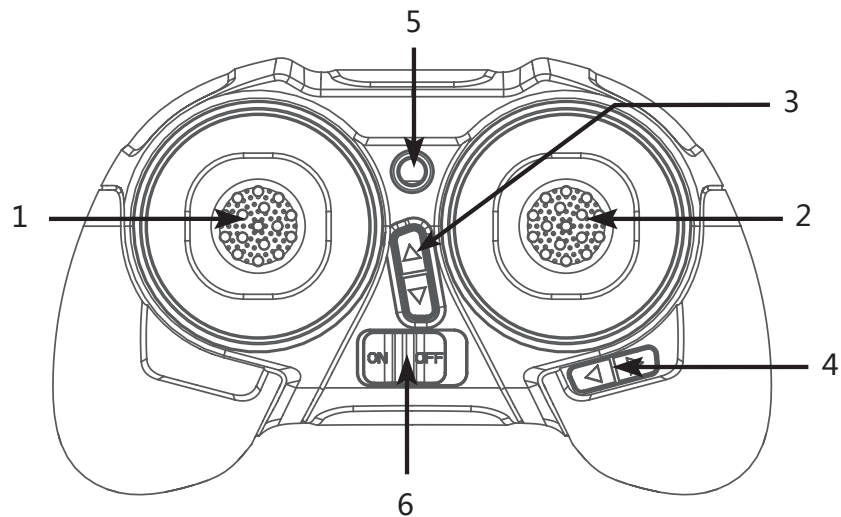

5.1 Input Key Function

S/N	Mode/ Control	Function
1	Mode 2 Throttle/ Rudder Stick	Push the stick forward or backward and the quadcopter will ascend or descend; Push the stick left or right and the quadcopter will rotate left or right.
2	Mode 2 Elevator/ Aileron Stick	Push the stick forward or backward and the quadcopter will fly forward or backward; Push the stick left or right and the quadcopter will fly left or right.
(2)	Mode 1 Throttle/ Aileron Stick	Push the stick forward or backward and the quadcopter will ascend or descend; Push the stick left or right and the quadcopter will fly left or right
(1)	Mode 1 Elevator/ Rudder Stick	Push the stick forward or backward and the quadcopter will fly forward or backward; Push the stick left or right and the quadcopter will rotate left or right.
3	Elevator Trim	Adjusts for forward and backward drift.
4	Aileron Trim	Adjusts for left and right drift.
5	LED Indicator	Blink in red before binding; Remain lighted in green after binding.
6	Power Switch	Remain lighted in red when in expert mode Turn on/off the remote controller.



- Do not mix old and new batteries
- Do not mix different types of batteries
- Do not charge non-rechargeable battery.

5.2 Quadcopter Calibration

Quadcopter calibration is required when the quadcopter drifts during flight. Land the quadcopter and place it on a horizontal surface for calibration.

Calibrating Procedures:

Mode 2: Push the left stick to the most right corner, and move the right stick left to right quickly, the 4 LED indicators on quadcopter will blink alternately, calibrationsucceeded when the indicators stop blinking.

Mode 1: Push the left stick to the most right corner, put the right stick to the lowest and move left to right quickly, the 4 LED indicators on quadcopter will blink alternately, calibration succeeded when the indicators stop blinking.

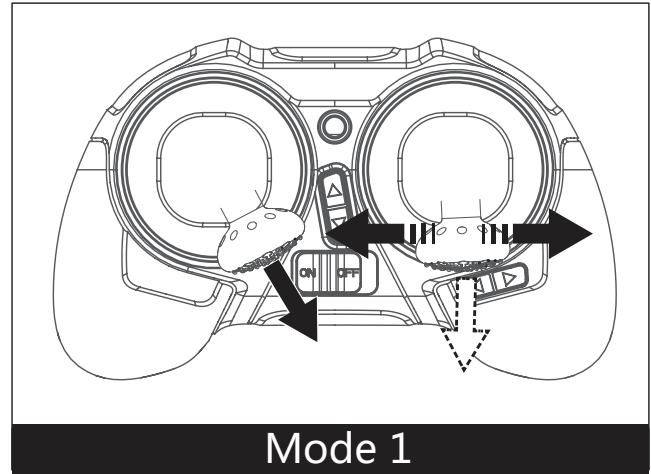
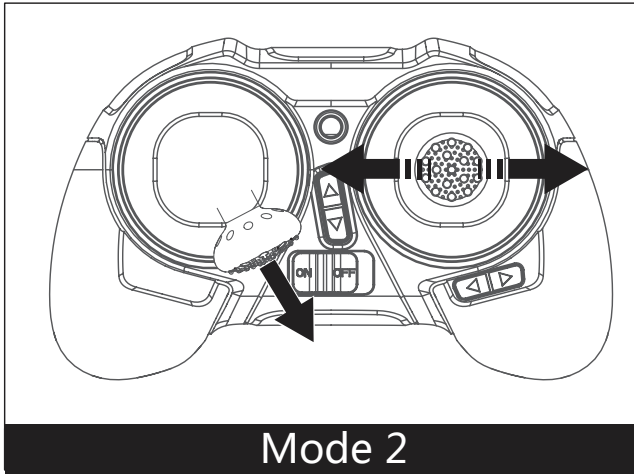

6 Camera

6.1 Long press the right Aileron Trim to start recording, indicated by 2 back LED blink slowly; Long press again to stop recording and save the video, indicated by 2 back LED stop blinking.

6.2 Long press the Elevator stick to take photo, indicated by 2 back LED blink once.

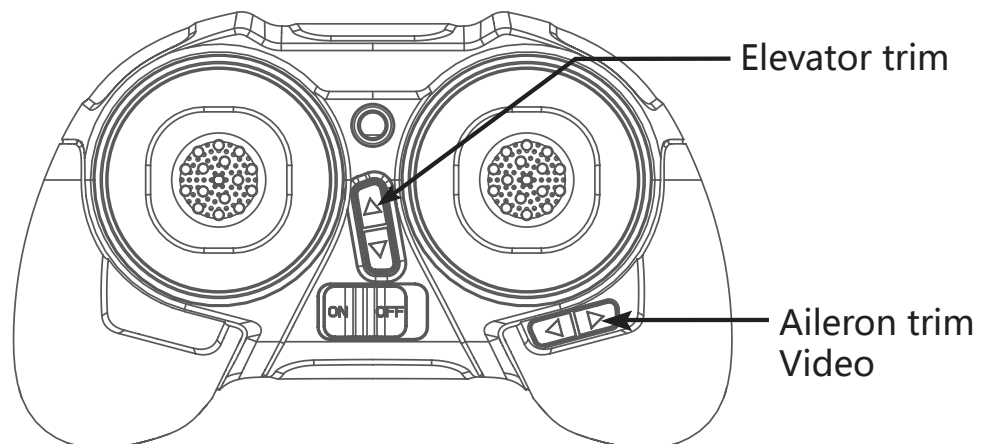

7 Start to Fly

7.1 Power-On

The quadcopter is designed with Power-On safety system, it ensures the motors will not start unless safety signals detected.

7.1.1 Turn on/off the remote controller by pushing power switch to left/right.

Make sure the Throttle stick is in the full down position, power on the remote controller, then quadcopter. Do not push any sticks or trims before pairing is succeeded, or the quadcopter will drift.

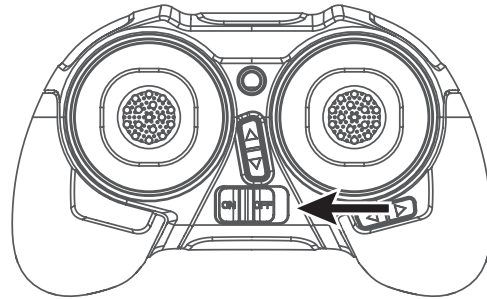
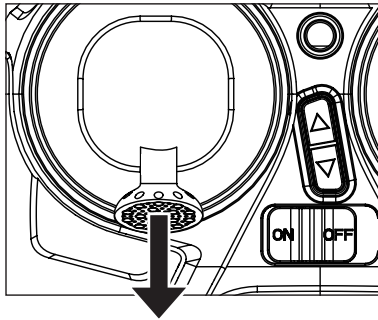

7.2 Basic Flight

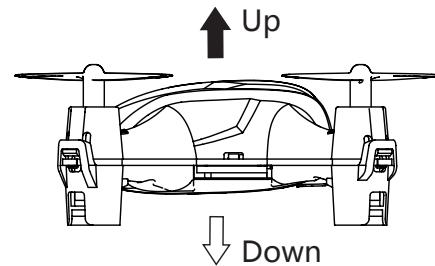
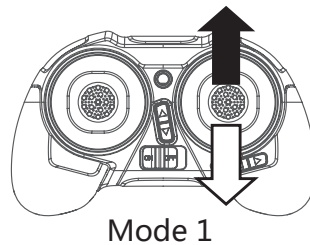
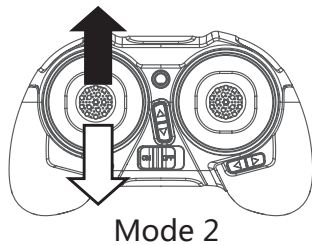

The throttle stick controls the ascent and descent.

Push up the stick and the X4 will ascend.

Pull down the stick and the X4 will descend.

Move the throttle stick above the center position to take off. (Move the stick gradually to prevent the X4 from ascending too quickly.)

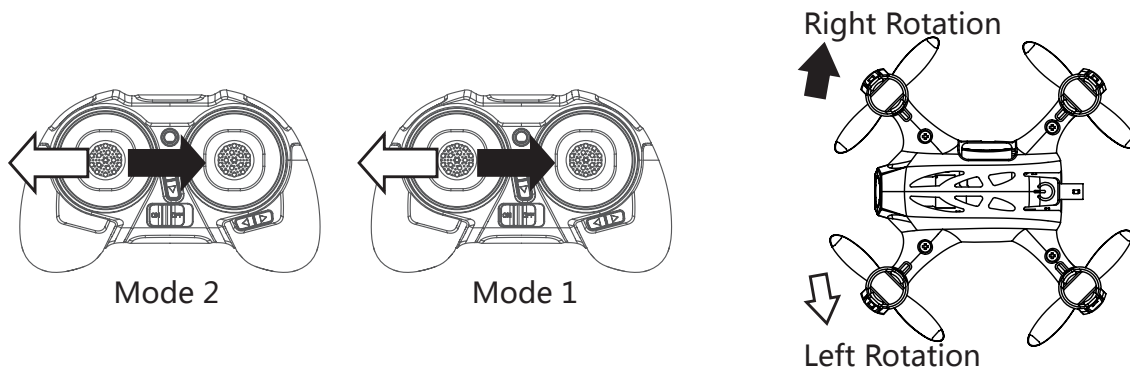

The Rudder stick controls the rotate direction
 Push the stick to the left and the X4 will rotate left
 Push the stick to the right and the X4 will rotate right
 Pushing harder will cause the X4 to rotate faster in the corresponding directions.

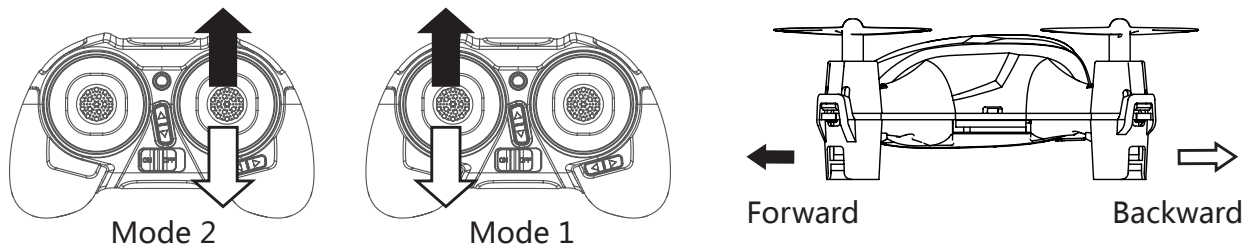

The Elevator stick moves the X4 forward and backward.
 Push the stick up the and the X4 will fly forward.
 Pull the stick down and the X4 will fly backward.
 The angle of stick movement corresponds to the angle of tilt and flight speed.

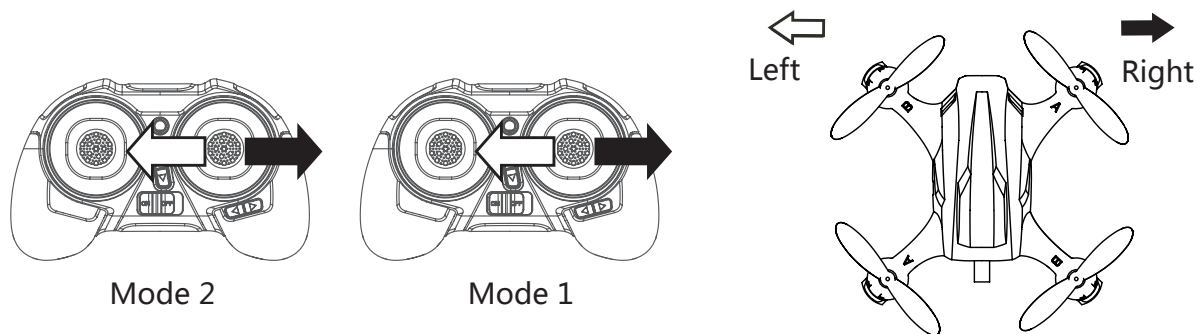

The Aileron stick controls left and right flight.
 Push the stick to the left and the X4 will fly to the left.
 Push the stick to the right and the X4 will fly to the right.
 The angle of stick movement corresponds to the angle of tilt and flight speed.

7.3 Headless Mode

Headless Mode means the quadcopter default any directions (corresponding to the directions of transmitter sticks) as its up head when the mode is activated. 2 front LED blink simultaneously when in Headless Mode.

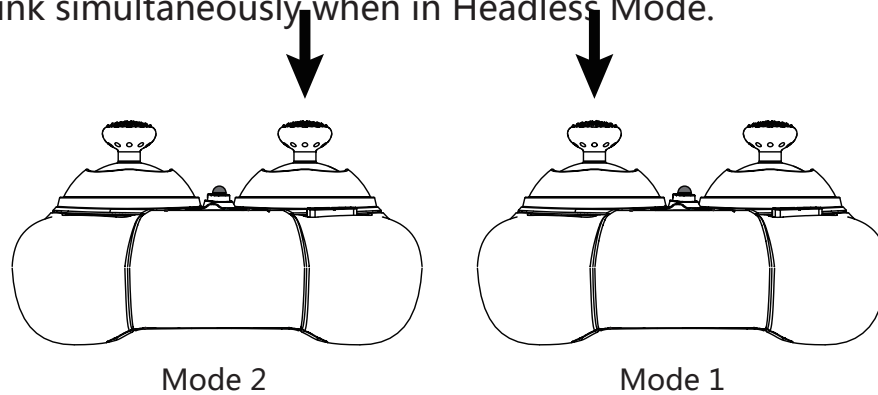

Short press the Throttle stick for to enter/exit headless mode.

Short press the Throttle stick to enter into the headless mode, indicated by two "Beeps" .

Short press the Throttle stick again to exit the headless mode, indicated by one "Beep" .

8 ADVANCED PERFORMANCE SETUP

Normal Mode/ Expert Mode The default setting is Normal Mode, and the Expert Mode can be activated to have a better sensitivity on the performance of the quadcopter.

Press the Elevator stick for 0.5 second to shift between Normal Mode and Expert Mode, indicated by "Beeps" .

9 Aerial Flip Mode

Long press the throttle stick to enter into Flip Mode, indicated by "Beeps" . The "Beeps" will last for 2 seconds. In this 2 seconds, push the accordance sticks to perform the flips.

9.1 Forward Flip

Push the Elevator stick forward quickly. Release the stick to the center after flip.

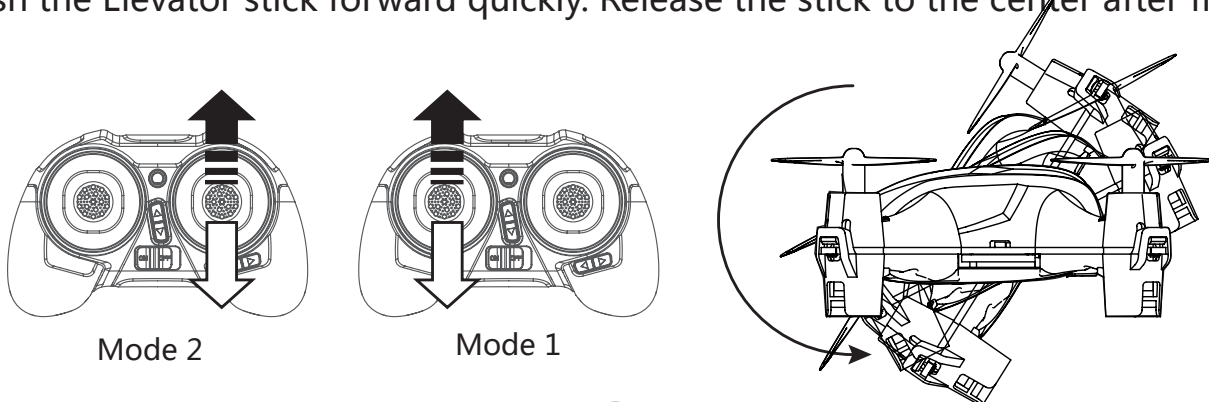

9.2 Backward Flip

Push the Elevator stick backward quickly. Release the stick to the center after flip.

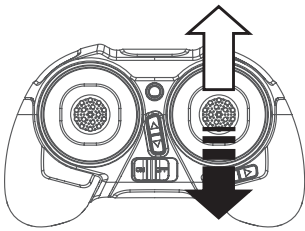

Mode 2

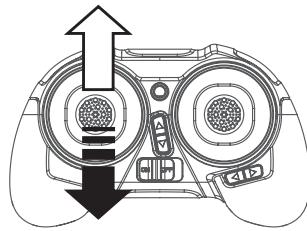

Mode 1

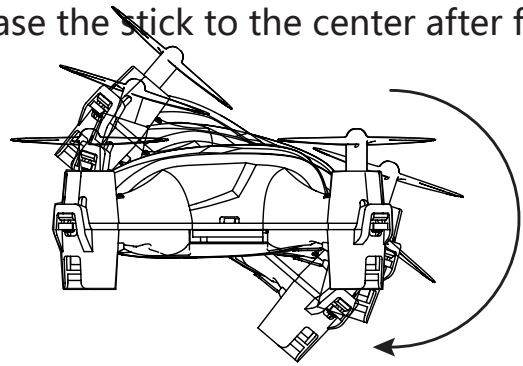

9.3 Left Flip

Push the Aileron stick to the left quickly. Release the stick to the center after flip.

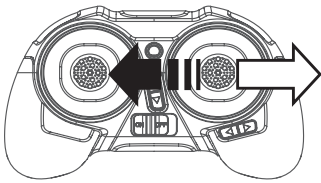

Mode 2

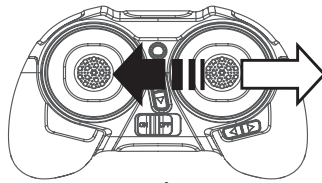

Mode 1

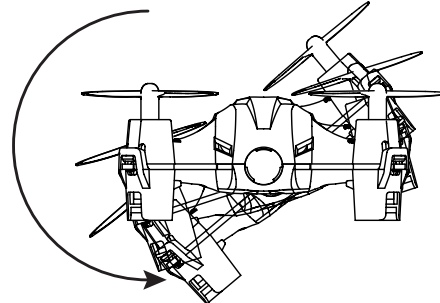

9.3 Right Flip

Push the Aileron stick to the right quickly. Release the stick to the center after flip.

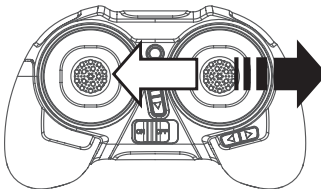

Mode 2

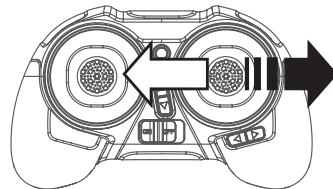

Mode 1

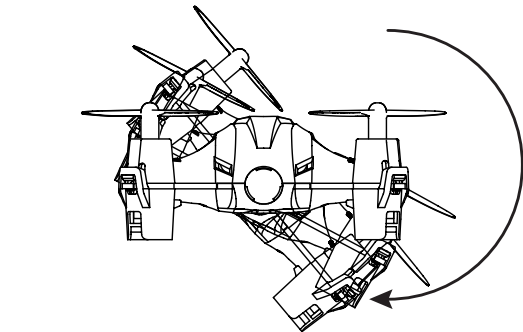

 Flip Mode is not available when battery is low.

10 Propellers

(1) Attach the propellers to the corresponding motors that are marked A and B;

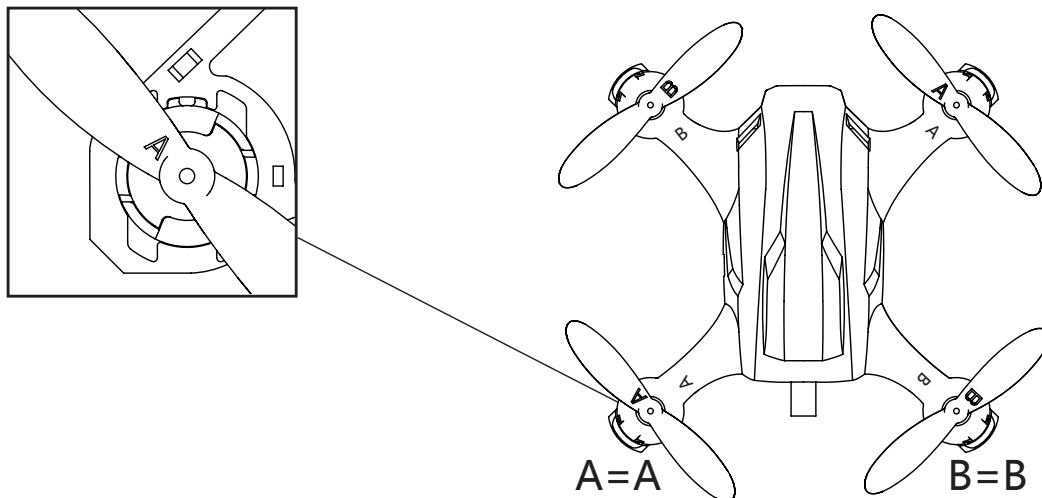

(2) Tighten the propellers to the motor shaft.

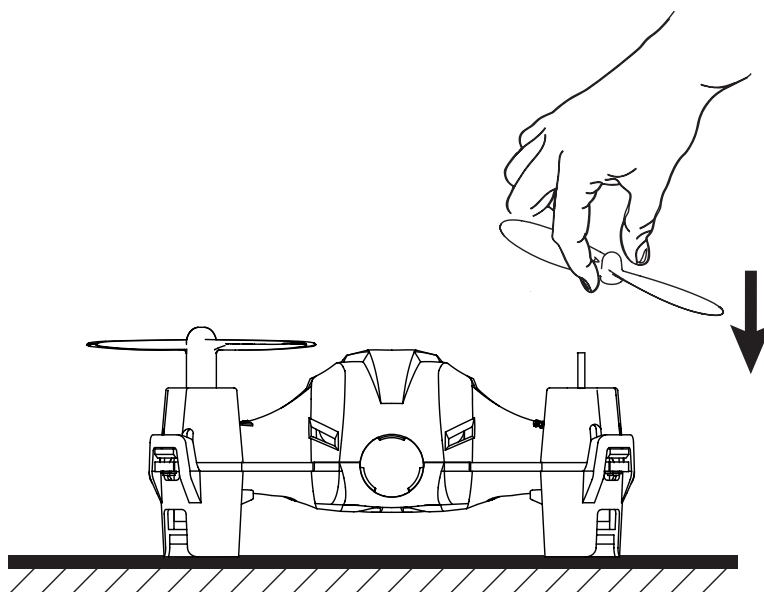

• Make sure that the A and B propellers are installed correctly. The quadcopter will not fly if propellers are improperly installed.

Exploded View

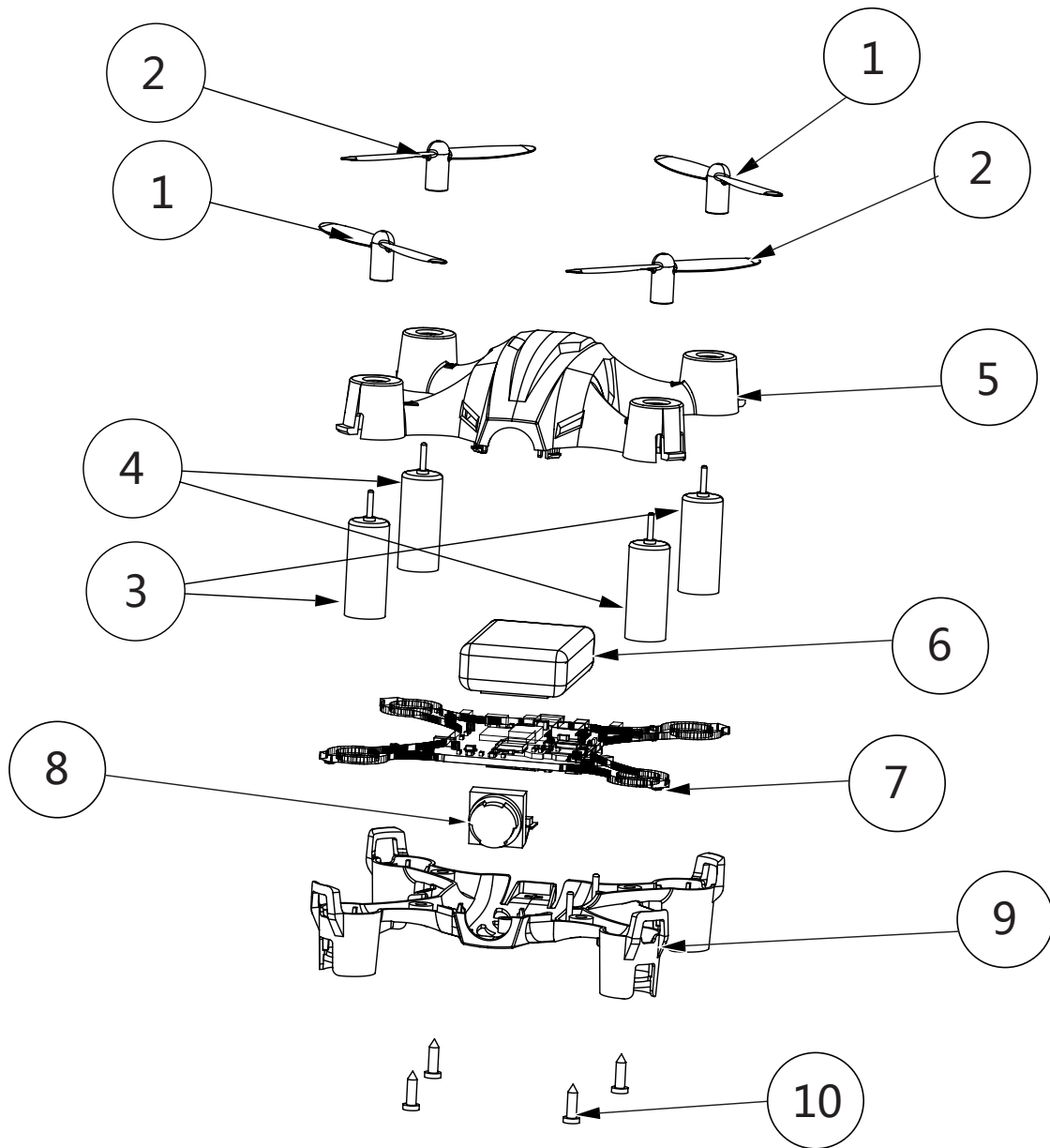

S/N	Part Name	Qty	S/N	Part Name	Qty
1	Propeller A	2	6	Li-Po Battery	1
2	Propeller B	2	7	PCBA	1
3	0614 Motor A	2	8	Camera	1
4	0614 Motor B	2	9	Lower Body Shell	1
5	Upper Body Shell	1	10	Screw	4

H002 TRROUBLESHOOTING

1. Transmitter and Quadcopter can not pair

Throttle position needs to be fully down. Please do not move any sticks or trims during initial power-on binding.

2. Gyro not Working Well

1) Battery voltage is too low ;

2) Re-bind ;

3) Land the quadcopter on the ground with the throttle stick fully down, take off again after 3 seconds.

3. Unable to Flip

Li-Po power is too low, re-charge the battery.

4. Quadcopter is shaking or making noise during flight

Check if motors, bodysells and propellers are all properly positioned or not;

Check if motors and propellers damaged or not.

5. Propellers work well, but cannot take off

Improper installation of the propellers. Check if the propeller A and propeller B installed correctly or not (As shown in below picture)

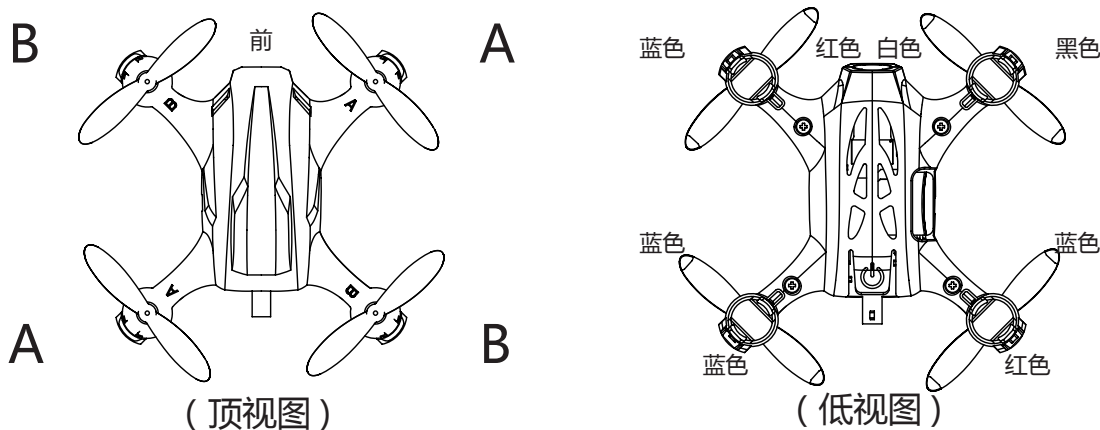

6. One or more motors stop working

1) Check if propellers squeeze motors;

2) Resolder if there is any broken motor connections.

3) Replace the motor.

7. Drifts

Make calibration as instructed below:

1) Make sure propellers, motors and quadcopter all in good condition, and the battery is connected correctly with full power, bind the quadcopter and remote controller

2) Calibrating Procedures:

Mode 2: Push the left stick to the most right corner, and move the right stick left to right quickly, the 4 LED indicators on quadcopter will blink alternately, calibration succeeded when the indicators stop blinking.

Mode 1: Push the left stick to the most right corner, put the right stick to the lowest and move left to right quickly, the 4 LED indicators on quadcopter will blink alternately, calibration succeeded when the indicators stop blinking.

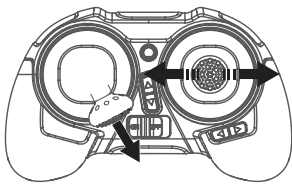

Mode 2

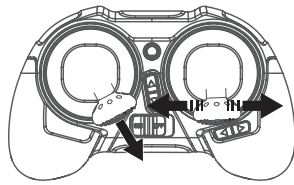

Mode 1

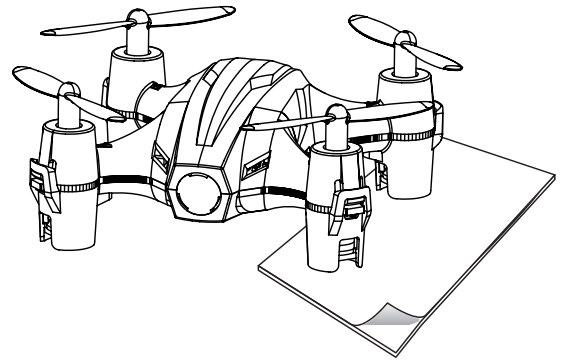

8.The camera can' t record

1) The SD card can' t be read by the quad. Please use MicroSD card (2-16GB, Class 4, UHS-1), Do not use any privated MicroSD.

2) Replace camera module

3) Format Micro-SD in the computer

H002 Spare Part List



H002-01
Body Shell Set



H002-02
Screw



H002-07
Propeller A/B



H002-03
Motor A/B



H002-04
2.4G Module



H002-05
Li-Po Battery



H002-06
Remote Controller



H111C-10
USB Charger

FCC Statement

Changes or modifications not expressly approved by the party responsible for compliance could void the user's authority to operate the equipment. This equipment has been tested and found to comply with the limits for a Class B digital device, pursuant to Part 15 of the FCC Rules. These limits are designed to provide reasonable protection against harmful interference in a residential installation. This equipment generates uses and can radiate radio frequency energy and, if not installed and used in accordance with the instructions, may cause harmful interference to radio communications. However, there is no guarantee that interference will not occur in a particular installation. If this equipment does cause harmful interference to radio or television reception, which can be determined by turning the equipment off and on, the user is encouraged to try to correct the interference by one or more of the following measures:

- Reorient or relocate the receiving antenna.
- Increase the separation between the equipment and receiver.
- Connect the equipment into an outlet on a circuit different from that to which the receiver is connected.
- Consult the dealer or an experienced radio/TV technician for help

This device complies with part 15 of the FCC rules. Operation is subject to the following two conditions (1) this device may not cause harmful interference, and (2) this device must accept any interference received, including interference that may cause undesired operation